

SMJシール

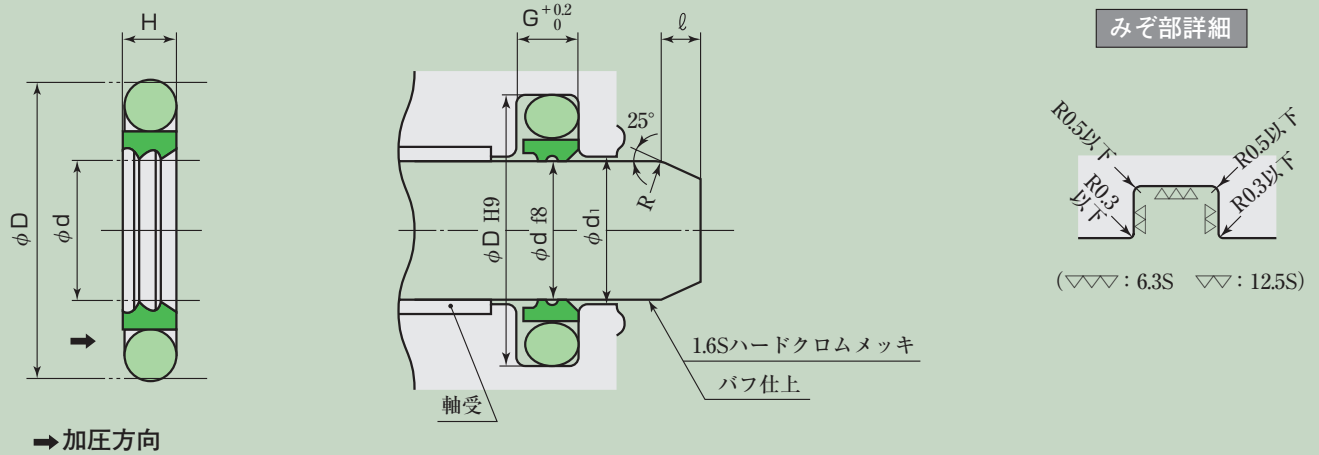

SMJシール寸法表

単位 : mm

呼び番号	パッキンおよびみぞ寸法						
	d	D	H	G	最大 d ₁		ℓ
標準 (PT 154)					(21MPa以下)	(35MPa以下)	
SMJ- 18	18	25.3	3	3.2	18.6	18.3	1.5
SMJ- 20	20	30.7	4	4.2	20.6	20.3	2
SMJ- 22	22	32.7	4	4.2	22.6	22.3	2
SMJ- 25	25	35.7	4	4.2	25.6	25.3	2
SMJ- 28	28	38.7	4	4.2	28.6	28.3	2
SMJ- 30	30	40.7	4	4.2	30.6	30.3	2
SMJ- 35	35	45.7	4	4.2	35.6	35.3	2
SMJ- 36	36	46.7	4	4.2	36.6	36.3	2
SMJ- 40	40	55.1	6	6.3	40.6	40.3	3
SMJ- 45	45	60.1	6	6.3	45.6	45.3	3
SMJ- 50	50	65.1	6	6.3	50.6	50.3	3
SMJ- 55	55	70.1	6	6.3	55.6	55.3	3
SMJ- 56	56	71.1	6	6.3	56.6	56.3	3
SMJ- 60	60	75.1	6	6.3	60.6	60.3	3
SMJ- 65	65	80.1	6	6.3	65.6	65.3	3
SMJ- 70	70	85.1	6	6.3	70.6	70.3	3
SMJ- 75	75	90.1	6	6.3	75.6	75.3	3
SMJ- 80	80	95.1	6	6.3	80.6	80.3	3
SMJ- 85	85	100.1	6	6.3	85.6	85.3	3
SMJ- 90	90	105.1	6	6.3	90.6	90.3	3
SMJ- 100	100	115.1	6	6.3	100.6	100.3	3
SMJ- 125	125	140.1	6	6.3	125.6	125.3	3
SMJ- 140	140	155.1	6	6.3	140.6	140.3	3

★ご注文・お問合せは、呼び番号にてご指示下さい。

★表中 呼び番号が色地のものは、在庫しております。