



GT/3

Guarnizioni per PISTONE
PISTON seals

TECNOTEX



Versione standard	Standard version
Base TPE V-Ring NBR + V-Ring Gommata Anello di testa POM	Base Ring TPE V-Ring NBR + V-Ring NBR/Cotton Fabric Header Ring POM
Versioni Alternative	Alternative Versions
GT FKM GT Tutta Tela	GT FKM All Cotton Fabric GT
Pressione fino a / Pressure up to	
40 MPa	
Velocità fino a / Speed up to	
0.5 m/s	
Temperatura / Temperature	
-30°C +110°C	-20°C +200°C FKM
Applicazioni	Applications
Presse Siderurgia Escavatori Macchine ad iniezione	Presses Steel Mills Excavators Injection moulding machines



Guarnizioni per PISTONE
PISTON seals

GT/3

138÷141

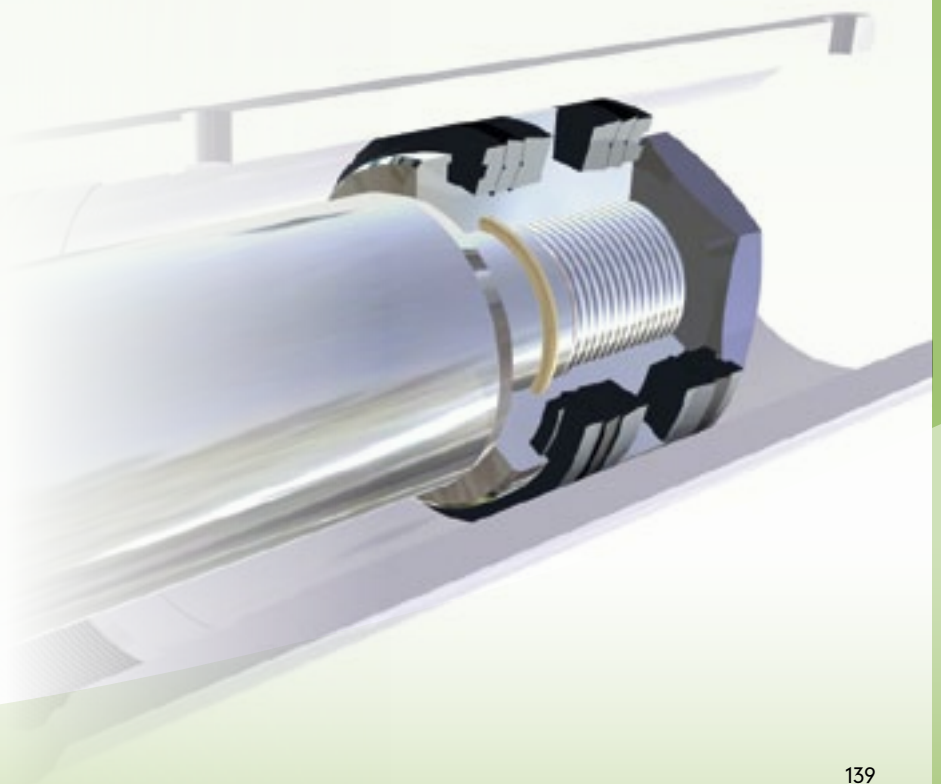

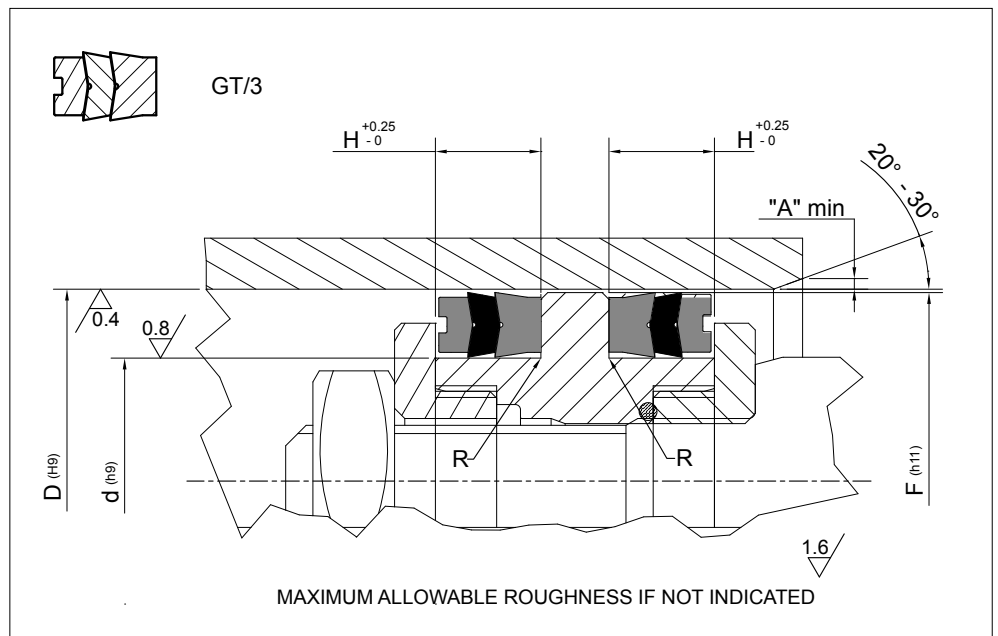

Piston Seal design guidelines

R	d ≤ 100mm		d > 100mm	
	max 0.40 mm		max 0.80 mm	
A	1 mm	2 mm	3 mm	3 mm < A ≤ 5 mm

PART NR		DIMENSIONI SEDI / Housing dimensions			
		D	d	H	F
GT3-20	078039	20,00	10,00	9,30	19,50
GT3-22	086047	22,00	12,00	9,30	21,50
GT3-25	098059	25,00	15,00	9,30	24,50
GT3-28	110070	28,00	18,00	9,30	27,50
GT3-30	118078	30,00	20,00	9,30	29,50
GT3-32	125078	32,00	20,00	10,90	31,00
GT3-35	137090	35,00	23,00	10,90	34,00
GT3-36	141094	36,00	24,00	10,90	35,00
GT3-40	157098	40,00	25,00	11,50	39,00
GT3-42	165106	42,00	27,00	11,50	41,00
GT3-45	177118	45,00	30,00	11,50	44,00
GT3-50	196137	50,00	35,00	11,50	49,00
GT3-55	216157	55,00	40,00	11,50	54,00
GT3-56	220161	56,00	41,00	11,50	55,00
GT3-60	236177	60,00	45,00	11,50	59,00
GT3-63	248188	63,00	48,00	13,00	62,00
GT3-70	275196	70,00	50,00	15,20	69,00
GT3-80	314236	80,00	60,00	15,20	79,00
GT3-90	354275	90,00	70,00	21,20	89,00
GT3-100	393314	100,00	80,00	21,20	99,00
GT3-110	433354	110,00	90,00	21,20	109,00
GT3-115	452374	115,00	95,00	21,20	114,00
GT3-125	492393	125,00	100,00	25,80	124,00
GT3-140	551452	140,00	115,00	25,80	139,00
GT3-150	590472	150,00	120,00	29,00	148,50
GT3-155	610492	155,00	125,00	34,00	153,50
GT3-160	629511	160,00	130,00	29,00	158,50

